

GARMIN PITCH TRIM SERVO UNIT - REMOVAL/INSTALLATION (Airplanes with GSM 86 Servo Mounts)

1. General

- A. This section gives the removal and installation procedures for the Garmin pitch trim servo unit for airplanes that have GSM 86 servo mounts.
- B. The GSA 81 and the GSM 86 are components of the Garmin Pitch Trim Unit. The GSA 81 is connected to the GSM 86 Servo Mount to form a single servo unit. Refer to Figure 401. Because of the design of the servo unit the servo portion (GSA 81) can be removed from the servo mount (GSM 86) without the need to de-rig the aircraft control cables. The pitch trim servo unit is located in the center console.

2. GSA 81 Pitch Trim Servo Removal/Installation

- A. Remove the GSA 81 Pitch Trim Servo (Refer to Figure 401).
 - (1) Remove external electrical power from the airplane.
 - (2) Make sure that the BATTERY switch (SC005), found on the circuit breaker switch panel, is set to the OFF position.
 - (3) Make sure that the EXTERNAL POWER switch (SC006), found on the circuit breaker switch panel, is set to the OFF position.
 - (4) Disengage the ELEV TRIM circuit breaker found on the left circuit breaker panel.
 - (5) Remove the screws and the washers that attach the right cover plate to the control pedestal.
 - (a) Remove the right cover plate from the control pedestal.
 - (6) Remove the screws and the washers that attach the left cover plate to the control pedestal.
 - (a) Remove the left cover plate from the control pedestal.
 - (7) Disconnect the servo electrical connector (PF304) from the pedestal wiring harness electrical connector.
 - (8) Remove the bolts and the washers that attach the servo from the servo mount.
 - (a) Remove the servo from the airplane.

NOTE: If the servo is removed for an extended time a cover can be installed on the servo mount to prevent contamination of the unit.

- B. Install the GSA 81 Pitch Trim Servo (Refer to Figure 401).
 - (1) Put the pitch trim servo in its correct position on the servo mount.
 - (a) Make sure that you align the servo mount gears and the servo gears correctly.
 - (2) Install the bolts and washers that attach the servo to the servo mount.
 - (a) Torque bolts to 35.0 inch-pounds, + 5.0 or -5.0 inch-pounds (3.95 N-m, 0.45 or -0.45 N-m).
 - (3) Visually inspect the electrical connectors to make sure that there are no bent or damaged pins.
 - (a) Repair any damage.
 - (4) Connect the servo electrical connector to the pedestal wiring harness electrical connector.
 - (5) Engage the ELEV TRIM circuit breaker found on the left circuit breaker panel.
 - (6) Load G1000 baseline software/configuration and certification gains to the pitch trim servo. Refer to Chapter 34 Garmin G1000 Integrated Avionics System - Adjustment/Test, G1000 Baseline Software/Configuration Load.
 - (7) Do an operation check of the pitch trim servo. Refer to Garmin GFC 700 Automatic Flight Control System (AFCS) - Adjustment/Test, Manual Electric Trim (MET) Switch Operational Check.

3. GSM 86 Pitch Trim Servo Mount Removal/Installation

- A. Remove the GSM 86 Pitch Trim Servo Mount (Refer to Figure 401).
 - (1) Remove the pitch trim servo from the mount. Refer to the GSA 81 Pitch Trim Servo Removal/Installation procedure in this section.
 - (2) Remove the nut and the washer that attach the elevator trim wheel to the shaft.
 - (a) Remove the elevator trim wheel from the shaft.
 - (3) Remove the screws that attach the chain cover to the left cover plate.
 - (a) Remove the chain cover from the left cover plate.

- (4) Remove the screws and detach the left cover plate from the control pedestal.
- (5) Loosen the bolts and move the support up to relieve the tension on the chain.
- (6) Remove the connecting link from the chain and disconnect the chain from the trim wheel sprocket.
- (7) Remove the servo mount.
 - (a) Remove the trim chain from the capstan:
 - 1 Remove the screws that attach the capstan cover and pins to the mount.

NOTE: Before you remove the cable retention pins record the installation position of each of the pins on the mount.
 - 2 Remove the capstan cover and pins.
 - 3 Record how the trim chain is installed on the servo mount capstan.
 - 4 Remove the trim chain from the servo mount capstan.
 - (b) Remove the four bolts that attach the mount to the servo mount bracket.
 - (c) Remove the servo mount from the airplane.

NOTE: If the servo mount is removed for an extended time a cover can be installed on the servo mount to prevent contamination of the unit.

B. Install the GSM 86 Autopilot Pitch Servo Mount (Refer to Figure 401).

- (1) Install the servo mount.
 - (a) Carefully the pitch trim servo mount in its correct position on the trim servo bracket.
 - 1 Install the four bolts that attach the servo mount to the trim servo bracket.
 - 2 Torque the bolts to 35 inch-pounds, +5.0 or -5.0 inch-pounds (3.95 N-m, +0.56 or -0.56 N-m).
- (2) Install the pitch trim servo to the mount. Refer to the GSA 81 Pitch Trim Servo Removal/Installation procedure in this section.
- (3) Install the pitch trim servo control chain.
 - (a) Install the trim chain on the trim wheel and servo mount capstan sprockets.
 - (b) Install the connecting link on the chain.
- (4) Put the elevator trim wheel in its correct position on the shaft.
 - (a) Install the nut and the washer that attach the elevator trim wheel to the shaft.
- (5) Install the capstan cover:
 - (a) Put each of the cable retention pins in one of the correct positions on the servo mount as follows:
 - C, G, L, N, and S.
 - (b) Put the capstan cover in its correct position on the mount retention pins.
 - (c) Install the screws that attach the capstan cover through the retention pins to the servo mount.
 - 1 Torque the screws to 10.0 inch-pounds +2.0 or -2.0 (1.12 N-m +.22 or -.22 N-m).
- (6) Do a check of the servo mount slip clutch. Refer to GSM Servo Slip Clutch Check.

NOTE: The GSM 86 slip clutch is not adjustable once manufactured. If the servo mount is not serviceable you must replace it.

4. Pitch Trim Rigging Check

- A. Do a check of the pitch trim rigging.
 - (1) Attach an inclinometer to the trim tab.
 - (2) Put the trim tab in the 0 degree position.
 - (3) Manually operate the trim tab to the up and down limits.
 - (a) Record the limits of travel.
 - (4) Have an observer at the right-hand access opening of the tailcone.
 - (5) Put the electrical trim to the full nose-up position until the observer sees the clutch slip.
 - (6) Turn the manual trim wheel nose-up (test load condition) 1/4 turn more while the clutch slips.

- (7) Make sure the swaged ball on the bridle cable assembly does not turn aft of the tangent point.
- (8) Release the trim wheel and disengage the autopilot.
- (9) Manually operate the trim to the full nose-up position.
- (10) Do a check of the trim tab position with an inclinometer.

NOTE: Trim tab position that is greater than the limits of travel values recorded is an indication that the stop blocks slipped.

- (11) If the stop blocks slip do the steps that follow.
 - (a) Do the trim system rigging again.
 - (b) Make sure the stop block bolts torque is correct.
 - (c) Do a check of the pitch trim rigging again.
- (12) If necessary make adjustments to the swaged ball position.
 - (a) Put the bridle cable assembly chain in the applicable position on the gear teeth of the actuator sprocket.

NOTE: One chain link adjustment is related to approximately 17 degrees of travel on the capstan.
 - (b) Apply the applicable tension to the bridle cable and do a check of the pitch trim rigging again.
- (13) Do the procedure again for the full nose-down trim condition.

Figure 401 : Sheet 1 : Autopilot Pitch Trim Servo Installation

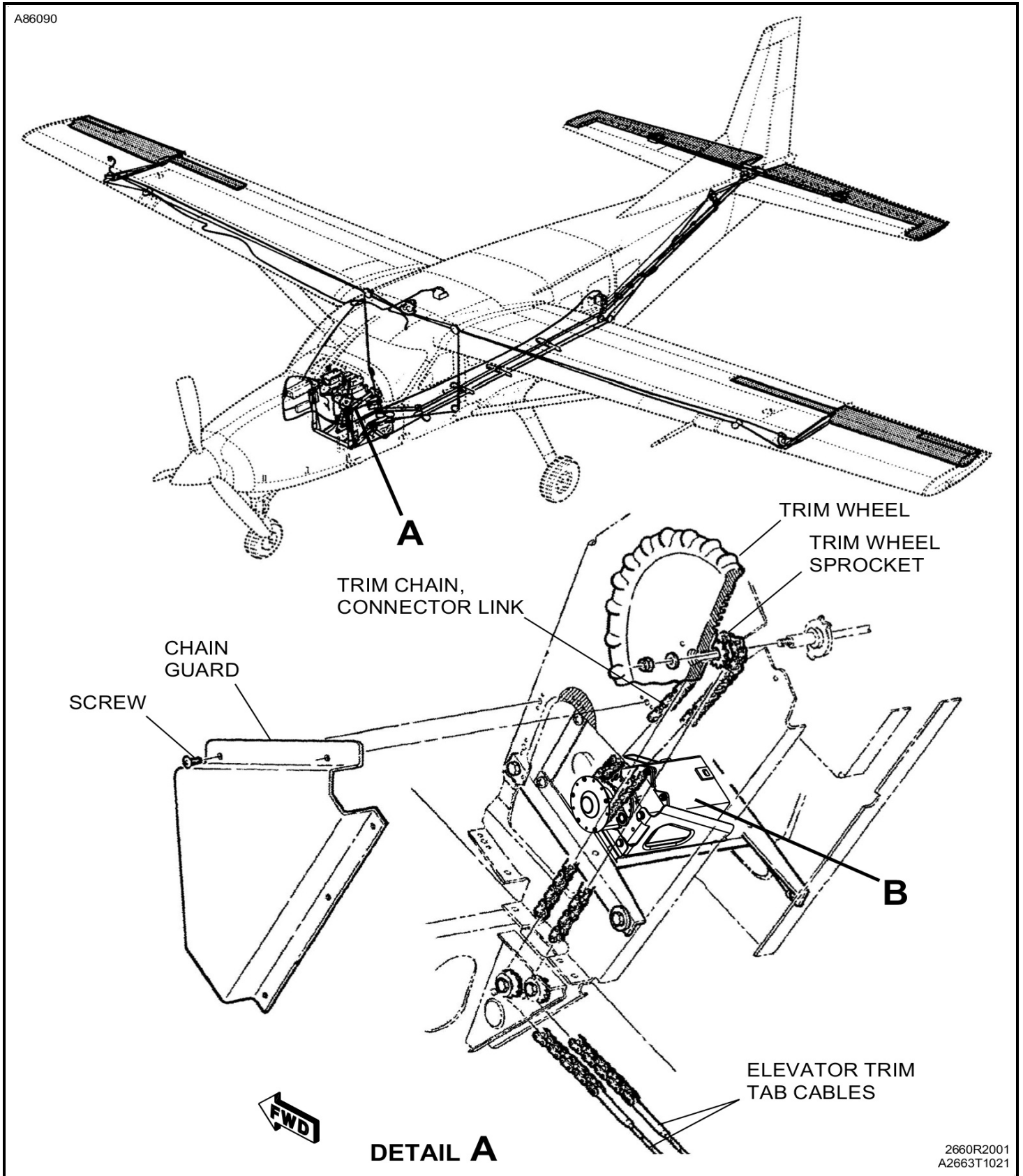
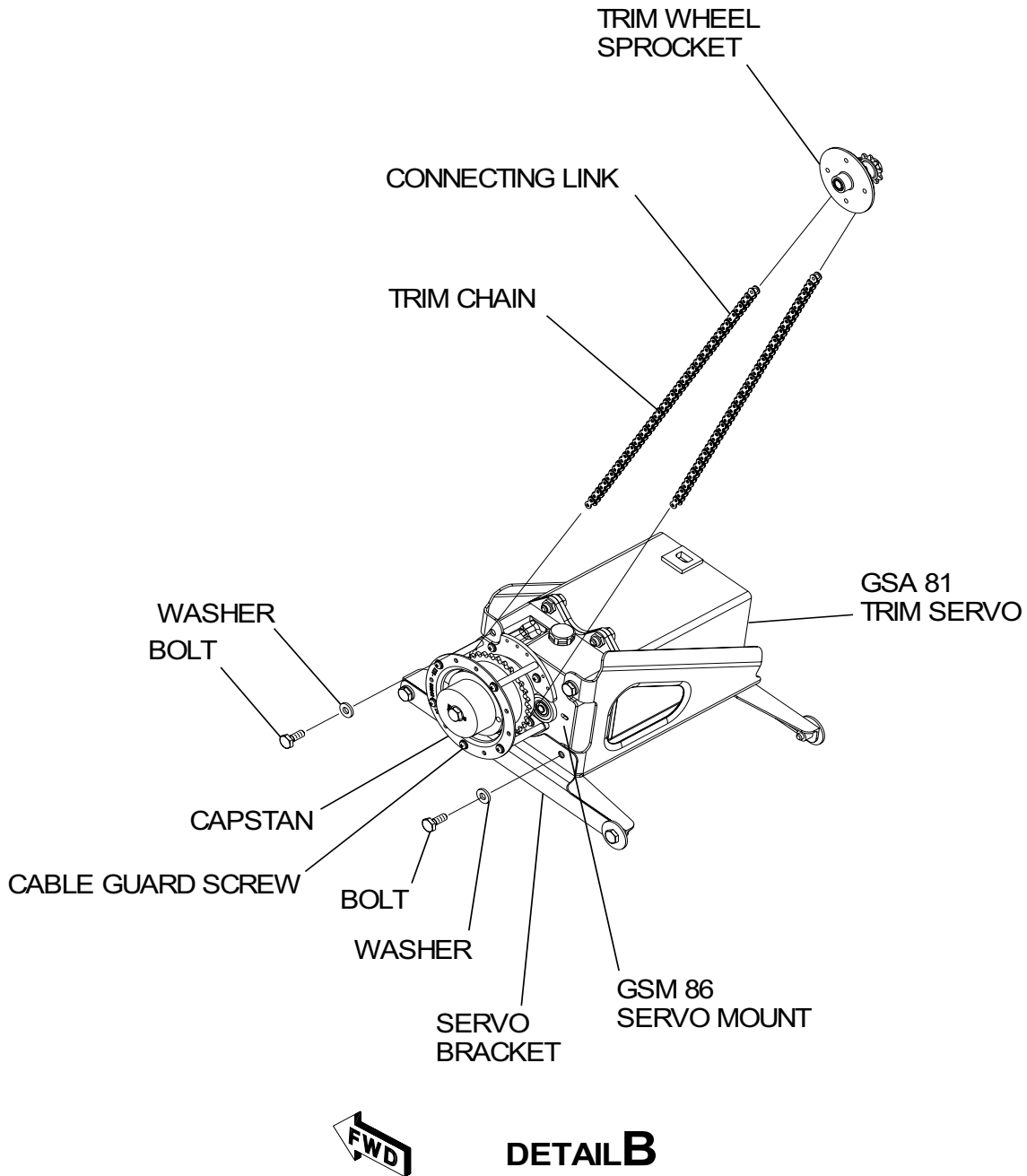

Figure 401 : Sheet 2 : Autopilot Pitch Trim Servo Installation

A86091



B2660T1017